

# Telecontrol-Interface-Module

## Type REG-PE

- As 19" rack version

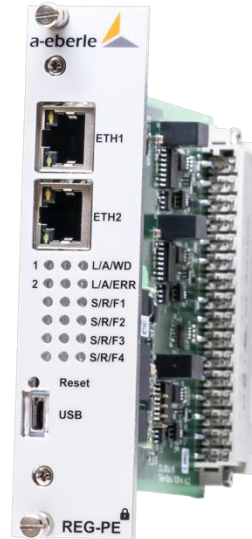

## 1. Application

The REG-PE operates as a coupling-device or protocol bridge between field devices – IEDs, Voltage regulators etc. and a local RTU or directly to a control centre. The REG-PE also operates as a communications processor that supports almost all important telecontrol protocols.

### 1.1 Features

The REG-PE...

- is conform to BDEW-Whitepaper and supports full Cybersecurity
- supports RBAC and RADIUS
- supports most important serial & Ethernet Tele-control Protocols including:
  - IEC 60870-5-101, 103 and 104
  - IEC 61850 (MMS & GOOSE)
  - DNP 3.00
  - SPABUS
  - MODBUS
  - C37.113
  - ELAN-Extension via Ethernet
  - NTP/PTP to DCF Time Synch Feature
  - SNMPv3
- multiple choices for connection such as copper, RS 485 and RS 232 or fibre-optics, (ST and SMA Connectors for baud rates from 300-115200 bd)
- Ethernet ports with integrated switch functionality (PRP/RSTP) can be:
  - DUAL-Fibre 100 Mbit LC MM
  - DUAL-Copper RJ45 (10/100 MBit)

- Coordinates the telegram traffic between one or more substation units, and with all possible connection types to central stations or substations
- Settings may be changed online at any time

### 1.2 Specification

The REG-PE board is equipped with a telecontrol-dedicated microcontroller and represents an independent computer with an on-board flash memory of 4 Gbyte (EMMC).

The CPU runs at a speed of 454 MHz. The board has a capacity of 128MB as working memory.

Depending on the size of the used micro-SD-card storage capacity for saving system device data, logging and manuals is up to 256 GB flash memory.

All twentyfour hardware-timers are required for the real-time Linux used.

Both of the processor-included UART - modules turn the four asynchronous V.24-interfaces. Each of these inter-faces have their own baud rate timers.

Serial interface 1-2 is able to work from 100 Bd. up to 921600 and serial interface 3-4 from 300 Bd. up to 921600 Bd.

For serial coupling in pulse-width-modulation (pulse-duration-modulation) 100 Bd. up to 2400 Bd. are available.

Despite the functions running by different software branches on REG-PE, there are general functions in order to protect the REG-PE module against malfunctions. These functions are realized by hardware supplements and by software parts.

We take care of it.

### 1.3 Interfaces

The REG-PE module offers the following interfaces for communication with parametrizing PC and for connection with serial communication partners:

- 10/100Mbit Ethernet
- up to 5 serial interfaces
- 4 of those serial interfaces RS485
- up to 4 serial fibre optic interfaces (optional)
- all transmitters and receivers are galvanically isolated by optocouplers
- all drivers are able to work as V24

Interfaces for serial communication are connected via rackmount connector. They include control lines, data lines and the requested power supply potentials. The status of each channel is shown on the 3 LEDs on the front panel.

### 1.4 Socket Connections on the Front

On the left-hand side of front panel, you see a Micro-USB-socket. This is used as serial port in order to supply e.g. parametrizing data. Via this connection you can easily parametrize REG-PE online at any time. It is also prepared to be used as OTG connector.

## 2. General Functions

Beside the functions, running by different software applications, there are main functions protecting against malfunctions of the device. These functions are realized by hardware-implementations and by software-routines:

### 2.1 Reset

There are four possibilities to trigger a reset on a REG-PE. A proper restart of REG-PE is guaranteed in each case:

- by pressing "RESET" on the front panel
- Watchdog runs up
- reconnection and return of power supply
- Reset by monitoring software module

### 2.2 Watchdog

Watchdog is a hardware-supplement to monitor the smooth process of the software. It consists of a timer that has to be triggered continuously by a background software program. Lack of retriggering leads to a hardware-reset. The correct status of watchdog is displayed by a red LED on the front panel near the Reset-button

### Note:

#### New REG-PE hardware "TK28-6" with Double-RJ45

Please pay attention to the following:

- The new hardware version TK28-6 has the a-eberle article number 111.9016.45, the article number is indicated on the side of the rating plate of the REG-PE.
- The new version has additionally to the already existing interfaces a micro-USB-Connector on the front. This new REG-PE enables the access at the internal micro-SD-card.
- Please use the new REG-PE commissioning files with version TK28-6, using the new data from the provided REG-PE commissioning CD.
- For commissioning support please contact: [comms-support@a-eberle.de](mailto:comms-support@a-eberle.de) or (+49) (0) 911 628108 0.

### 2.3 Contact Positions for SCCs and Power

Pin	d	b	z
2	FREMD-P	FREMD-N	PROZA
4	COM4-GND	485-4-N-T	485-4-P-T
6	COM4-CTS	485-N-4	COM4-RTS
8	COM4-RXD	485-P-4	COM4-TXD
10	COM3-GND	485-3-N-T	485-3-P-T
12	COM3-CTS	485-N-3	COM3-RTS
14	COM3-RXD	485-P-3	COM3-TXD
16	COM2-GND	485-2-N-T	485-2-P-T
18	COM2-CTS	485-N-2	COM2-RTS
20	COM2-RXD	485-P-2	COM2-TXD
22	COM1-GND	485-1-N-T	485-1-P-T
24	COM1-CTS	485-N-1	COM1-RTS
26	COM1-RXD	485-P-1	COM1-TXD
28	PE	PE	PE
30	GND	GND	GND
32	VCC	VCC	VCC

### 3. Technical Data

<b>Processor</b>	i.MX28
Processor technology	CMOS
Memory	128 MBit RAM
Operation system	Realtime, Linux
<b>Serial interfaces</b>	max. 6
Input-resistance	1000 Ohm
Output-resistance	120 Ohm
Input voltage	± 3 ... 12 V
<b>Power supply</b>	+ 5 V ± 10 % 0.6 A max.
<b>Reference conditions during operation in a 19" rack:</b>	
Temperature:	- 10... + 55 °C
Relative humidity:	max. 85 % at 25 °C
<b>Reference conditions during storage:</b>	
Temperature:	- 25... + 65 °C
Relative humidity:	max. 80 % at 25 °C

#### 3.1 Applied Rules and Standards

- IEC 61010-1 / EN61010-1
- IEC 60255-22-1 / EN 60255-22-1
- IEC 60529 / EN 60529
- ICE 60068-1 / EN 60068-1
- ICE 61000-6-2 / EN 61000-6-2
- ICE 61000-6-4 / EN 61000-6-4

#### 3.2 Mechanical Construction

Front panel	ALU, RAL 7035
Height, Width	3U, 6T (129 mm, 71 mm)
Weight	≤ 0.4 kg

##### Protection class

Plug-in device	IP 00
Terminal block	IP 00

**Mounting** according to DIN 41494 Part 5/DIN 41612

Connector block

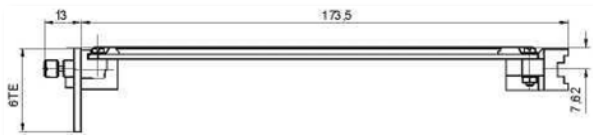

Picture 1: Dimensions plug-in module

#### 3.3 Data programming cable Micro-USB

Cable has to be shielded and may not be longer than 1.5 m.

#### 3.4 Housing

Terminal screws with self-locking protection; clip on connector block

#### 3.5 Operating Modes

The telecontrol board REG-PE has got no jumpers on board. In order to switch between the operating modes RS485 and RS232 (fibre-optic mode is done via RS232 mode and additional piggy back module) a software parameter has to be set accordingly.



We take care of it.

## 4. Electric Security

Protection class 1  
 Grade of pollution 2  
 Overvoltage category, rated isolation voltage

Name	Overvoltage	Max. Overvoltage
Serial interfaces	II	50 V front
Serial interfaces	II	350 V back

**Transient voltage** 5 kV, 1.2/50 ms, 0.5 Ws  
**Strength immunity**  
 Electrostatic Air load 8 kV  
 discharge Contact load 4 kV  
 Electromagnetic fields 80 MHz...1000 MHz 10 V/m  
 900 MHz ± 5 MHz 10 V/m  
 pulse modulated

### Rapid transient disturbance quantities (Bursts)

Power supply AC 230 V: 2 kV  
 Data signal lines 1 kV  
**Contacted RF-disturbance factors** 0,15 MHz...80 MHz  
 $U_{eff} = 10 V$   
**50 Hz- magnetic field** 30 A / m  
**Disturbance emission** Group 1 /limit class A

### 4.1 RS485-Processing

In order to terminate the RS485-bus you should use an external termination resistor.

### 4.2 Non-Ethernet Fibre-optic Connectors

All connectors have SMA/ST-standard-size. The wavelength is at 660/850nm and is ready for glas and plastic fibre-optics.

#### Jumpersettings fibre-optic board

Jumper	Meaning
X5-1	Receiver invert
X6-1	Transmitter invert

### 4.3 Commissioning of the Board

For commissioning purposes, a quick guide and an elaborately user manual with parameterizing guide is coming with the board and also downloadable on our home page. A generated file is transferred via micro-SD or Ethernet interface from a standard PC into REG-PE. Data is kept in flash memory.

## 4.4 Fields of Application

The telecontrol board REG-PE processes the following telecontrol protocols together with Eberle devices:

- IEC 870-5-101, 103 and 104
- IEC 61850
- DNP3.0
- MODBUS
- SPABUS
- C37.113
- NTP/PTP to DCF Time Synch Feature
- ELAN-Extension (CSE, COM Server Ethernet): Extension of ELAN via serial port of REG-PED over Ethernet in order to connect to another REG-PE(D) via Ethernet in order to achieve wide area ELAN. Fully equipped REG-PED provided.
- Other protocols on demand
- The telecontrol connection can be made via RS232, RS485 and fibre optics.
- The parameterizing is done in two main sections:
- Common part where only baud rate and device address have to entered
- Advanced part where specialist may adjust specifics.

This implies timeouts etc. and other protocol specifics as well as modification possibilities of the telecontrol profiles.

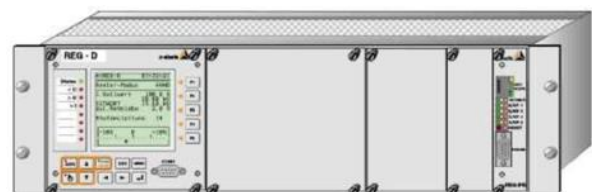

Picture 2: Example of mounting in 19"-rack

## 5. B3 Mounting

Besides the mounting version for 19" rack and wall mounting version there is a DIN rail version available:

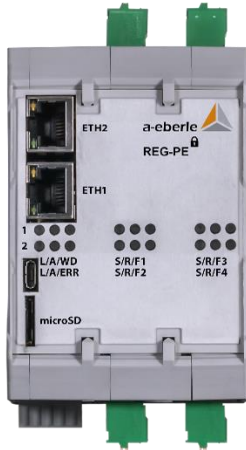

- 1 serial interface is RS232 only and can be found on X1:

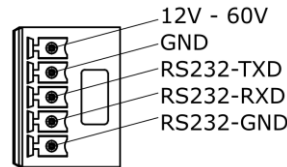

### 5.3 Assignment of COM-Ports

COM-Ports one to five can be found on following connectors:

- COM1: X2
- COM2: X4
- COM3: X3
- COM4: X5
- PARAM / aux. power: X1

### 5.1 Power supply

Power supply comes via connector X1

- 12 V to 60V DC
- Absolute maximum: never more than 62V DC

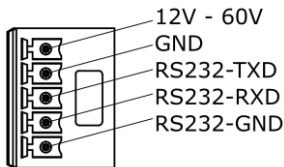

### 5.4 Ethernet

There are two Ethernet-Ports with a max. transmission speed of 100Mbit. They can be ordered either electric with RJ45 connector or optical with LC-connector, or mix with one electrical and one optical connector.

### 5.5 Micro-USB and microSD

At the front there is a micro-USB connector, which allows you console access for commissioning purpose.

The microSD-Slot (microSDHC) at the front may be used for logging purposes.

### 5.2 Serial interfaces

All five following serial interfaces are optical isolated and therefore the respective GND as base potential.

- 4 serial interfaces for telecontrol purposes, that comprise RS232 and RS485. They can be found on X2 to X5 and are all pin compatible. Additionally, isolated 5V DC are available on each connector within max. 100mA load.

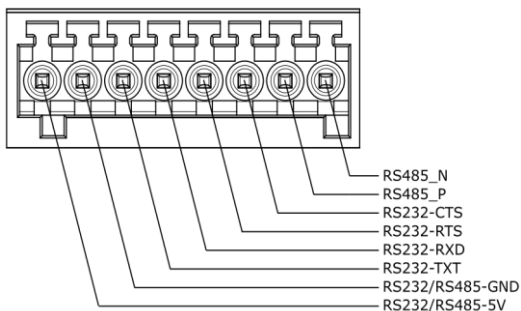

We take care of it.

## 6. Upgrade Features

### Always available protocols:

- DNP3 serial and Ethernet
- IEC 101, 103, 104
- COM Server
- Modbus RTU and Ethernet
- SPABUS
- IEC 61850 (MMS&GOOSE)
- PTP+NTP
- C37.118
- PRP
- RSTP
- COM Server on separate NIC

### Upgradable to:

- SNMPv3

### 6.1 Example Applications:

#### A) COM Server

a) COM Server Only Application: Up to 4 COM ports serve both Ethernet connections, assuming that the 2 Ethernet addresses are different. Example: IP address of Port 1 is set to 192.168.1.214 and IP address of Port 2 is set to 10.0.0.215, or “bonding” in “active backup mode” or RSTP was selected, then both Ethernet interfaces have same IP and MAC address.

b) ELAN-Extension (CSE, COM Server Ethernet): Extension of ELAN via serial port of REG-PED<sup>SV</sup> over Ethernet in order to connect to another REG-PE(D) via Ethernet in order to achieve wide area ELAN.

#### B) Dedicated Protocol Application

a) Working as a telecontrol board for customer specific devices starting with IEC 60870-5-103 or 104 telecontrol protocols e.g.: for the substation connection of A. Eberle devices, you can easily update later to IEC 61850 by firmware update, no hardware change is needed.

b) Working as a protocol router

- IEC 60870-5-101 to IEC 60870-5-104  
Up to 4 COM ports may be used to connect the Router to IEC 60870-5-101 lines of several substations, to multiple control centres via IEC 60870-5-104. The only settings required for this application is to simply entering addresses and baud rate.
- IEC 60870-5-103 to IEC 60870-5-101  
With the help of fibre-optic star couplers of you may connect up to 8 IEC 103 devices to one COM port of a REG-PED<sup>SV</sup> board, and route information to another COM port with IEC 101 protocol.
- IEC 61850 to IEC 60870-5-104  
One ethernet port may be connected to IEC 61850 and the other Ethernet port to IEC 60870-5-101, or both protocols may be operated from the same ethernet port.
- IEC 61850 to IEC 60870-5-103  
Router works as slave for IEC 60870-5-103 master and client for IEC 61850.

#### C) Mixed Ethernet Operation

If you order one Ethernet port with electrical RJ45 connector, and the other Ethernet port with fibre-optic connector, you are free to choose the connector type. Even combined use of both ports is possible.

#### General Information concerning Dual Ethernet Connectors

Both Ethernet connectors may be merged to one logically interface using so called “bonding feature” in “broadcast mode” or RSTP, where both Ethernet interfaces have same IP and MAC address. Additionally they can be set in PRP as well as RSTP mode.

**„Modbus Collector“ for REG-PE - a real highlight:**  
Using Modbus-Master functionality, the device will collect sensor data from arbitrary Modbus-slaves. Use this data for example to support regulation function by sending it to regulating devices or in fact to any receiver via IEC 61850. This functionality is a replacement for the „COM3-Extension“.

**IEC61850 support for REG-DGA** via Modbus Collector - collect data from up to 32 Modbus devices and make them available via one virtual IEC 61850 device.

#### Data acquisition according to IEC61850-9-2 (“Process-Bus”)

At the moment only available as REG-PED<sup>SV</sup>.

## Ordering Details

- Only one code of the same capital letter is possible
- When the capital letter is followed by number 9, further details are necessary
- The code can be omitted when the capital letter is followed by zero

Telecontrol Interface Module with Cyber Security		
Characteristics		Code
<b>Protocol interface unit (6PU, 3HU)</b> for connection of REGSys™ devices to a SCADA system for serial and Ethernet based protocols like IEC 61850; incl. parametrization tool WinConfig <b>Note:</b> REG-PE can also be used as COM-Server <b>For FO connection either characteristic H11 (RED-D) or REG-NTZ is mandatory.</b>		REG-PE
<b>Design</b> Plug-in unit Wall mounting version (20TE, 3HE) wired; incl. wiring for power supply DIN rail case mounting, 12-60 V DV, excl. power supply Installation with other REGSys™ components		B01 B02 B03 B09
<b>With IT-Security - feature is mandatory starting from TK28-6 board type.</b>		I1
<b>Usage of board</b> COM-Server only telecontrolling of a REG-D(A) telecontrolling of a REG-DP(A) telecontrolling of a EOR-D telecontrolling of a PQI-D telecontrolling of a DMR-D for connection of combinations of REG-D/DP, EOR-D... <b>Note:</b> L9 can only be used with Z15...Z19, Z91, Z31, Z92		L0 L1 L2 L3 L4 L5 L9
<b>Type of connection (SCADA):</b> <b>Standard</b> RJ 45 1 x RS 232 RS 485; two-wire operation only		V00 V10 V11
<b>Note:</b> V13 ... V19 only in combination with B2 or B9. <b>For all other cases choose a suitable fibre optic module.</b>		
<b>Fibre optic with ST</b> for IEC 61850, IEC 60870-5-104, or DNP3.0 via Ethernet <b>Fibre optic with LC</b> for IEC 61850, IEC 60870-5-104, or DNP3.0 via Ethernet Excluding module mounting (see tab "Racks Interf."), module on back side of rack <b>Fibre optic; connection with FSMA for ..101/..103/MODBUS (incl. module mounting)</b> Glass (wavelength 800...900 nm, distance < 2000 m) Plastic (wavelength 620...680 nm, distance < 50 m) <b>Fibre optic; connection with ST for ..101/..103/MODBUS (incl. module mounting)</b> Glass (wavelength 800...900 nm, distance < 2000 m) Plastic (wavelength 620...680 nm, distance < 50 m) <b>Fibre optic; connection with VL for ..SBABUS (incl. module mounting)</b> Plastic (wavelength 620...680 nm, distance < 50 m)		V12 V14 V13 V15 V17 V19 V22

<p><b>Design of Ethernet Ports</b></p> <p>2x RJ45 front connection 10/100 Mbit          1x RJ45 and 1x glass fibre 100 Mbit (front connection, Multimode, LC)          2x glass fibre 100 Mbit (front connection Multimode, LC)          If you need rear fibre connection or Gbit Ethernet please select REG-PED<sup>SV</sup></p>		<p>D94 D96 D98</p>
<p><b>Protocol</b></p> <p>IEC 60870-5-103 for ABB          IEC 60870-5-103 for Alstom / Schneider-Electric          IEC60870-5-103 for Siemens (ex SAT: 1703)          IEC 60870-5-103 for Siemens (LSA/SAS)          IEC 60870-5-103 for Sprecher Automation          IEC 60870-5-103 for others          IEC 60870-5-101          DNP 3.0 (connection V10 or V11)          COM Server          DNP 3.00 via Ethernet (connection V00 or V12)          SPABUS          MODBUS RTU          MODBUS TCP/IP          IEC 61850          IEC 60870-5-104</p>		<p>Z10 Z11 Z12 Z13 Z14 Z90 Z91 Z20 Z09 Z21 Z22 Z23 Z24 Z31 Z92</p>



**A. Eberle GmbH & Co. KG**

Frankenstraße 160  
 D-90461 Nürnberg  
 Tel +49 (0) 911 / 62 81 08-0  
 Fax +49 (0) 911 / 62 81 08-96  
 info@a-eberle.de  
 www.a-eberle.de

Copyright 2020 A. Eberle GmbH & Co. KG  
 All data may be subject to change without prior notice.

Telecontrol-Interface-Module – REG-PE

Presented by:

---