

MAVOSPEC
Spectrometer



Thank you for selecting this state of the art GOSSEN product. We hope you are enjoying the easy operation, the high quality, precision and wide functionality.

Please check that the spectrometer and accessories as detailed below are included in the carrying case. If the contents are incomplete, please contact your local dealer.

- MAVOSPEC Spectrometer
- MicroSD memory card (in slot)
- Power supply and USB cable
- Carrying strap
- CD (includes operating instructions)
- Aluminium transport case

MAVOSPEC key features

- **Illuminance** measurement, cosine corrected, accuracy per class B.
- **Large dynamic range** from 1 to 200 000 lx, highest resolution of 0.01 lx
- **Spectral power distribution** measurement, large range of 340 to 750 nm
- **Chromaticity, color coordinates** measurement in accordance with CIE 1931 [x,y], CIE 1960 [u,v], CIE 1976 [u', v'] and display of the CIE color table.
- **Light quality** measurement, correlated color temperature CCT and color rendering index Ra, as well as individual indices R1 through R14.
- **Outstanding measured value stability** by automatic temperature compensation
- **Individual calibration**, photometrically and radiometrically before delivery
- **Simple functions expansion** with optional measuring accessories
- **Intelligent accessories detection** with coded measuring accessories.
- **Convenient daily use** – Intuitive operation via touch-screen, easily legible high resolution color display, compact design, high-quality aluminum transport case
- **Automatic measured value storage** on interchangeable 4 GB micro SD card.
- **Easy data transfer** to any desired program by XML data format
- **Universal interfaces** USB and WiFi for convenient data exchange
- **Synchronization with measuring systems** by trigger input / output
- **Stationary measurement setups** by ¼" tripod thread on the back

Contents	Page
Safety Precautions, Warnings, Notes	4
1 Preparation	
1.1 Overview	7
1.2 Charging Instructions and Battery Care	7
2 MAVOSPEC Software	
2.1 Home Screen	8
2.2 Config Screen	9
2.3 Spectrum Screen	10
2.4 Result Screen	11
2.5 CIE Chart Screen	11
2.6 Data Screen	12
2.7 Library Screen	12
2.7.1 Directories Screen	13
2.8 Settings Screen	14
2.8.1 Battery Status	14
2.8.2 Wi-Fi Settings	14
2.8.3 Idle Time	16
2.8.4 Date & Time Settings	16
2.8.5 Status	17
2.8.6 Info	17
3 Trigger Input / Output	18
4 Accessories	
4.1 Integrating Sphere – MAVOSPHERE 48	21
4.2 Display Sensor – MAVOSPROBE 1.0	22
4.3 Software – GL SPECTROSOFT BASIC	23
4.4 Software – GL SPECTROSOFT PRO	24
5 Calibration	
5.1 Spectral Calibration and Maintenance	25
5.2 Factory Calibration Certificate Luminance or Illuminance	25
5.3 DAkkS Calibration Certificate Illuminance	25
6 Service and Maintenance	26
7 Technical Specifications	27

Safety Precautions

Please read these safety precautions carefully before using your measuring device. This will help you to avoid damaging the product and prevent personal injury.



This icon identifies important warnings which should be read in any case before the initial start-up of your GOSSEN product.

Warnings



In the event of malfunction, switch off the measuring device immediately.

If the event that smoke develops or unusual odors become apparent, which are caused by either the measuring device or the power supply, disconnect from mains power immediately and remove the rechargeable battery from the meter in order to prevent possible fire. Continuing to operate the measuring device or the power supply after such malfunctions have occurred may result in severe injury. Please contact your local dealer or GOSSEN-Service in order to eliminate malfunctioning. If you bring or send the meter in for repairs, make sure that the rechargeable battery has been removed first.



Never use the measuring device in proximity to flammable gases.

Electronic devices must not be used near flammable gases. Otherwise there would be danger of explosion and fire.



Never hang the meter and/or the carrying strap around the head or neck of a child.

Danger of strangulation exists if the carrying strap is hung around the head or neck of a child.



Store the measuring device at a location which cannot be accessed by children.

The measuring device and its accessories include parts which can be swallowed. Make sure that these parts (e.g. housing covers, rechargeable batteries etc.) do not fall into the hands of children who might swallow them. Otherwise, danger of suffocation prevails.



Use suitable cables only.

Use only the included, original GOSSEN cables for connection to external devices. GOSSEN assumes no liability if other cables are used.



Do not dismantle the measuring device.

Never touch any parts located inside of the housing – injury may result. Never attempt to repair the meter yourself or try to open the meter. Repairs may only be made by qualified personnel. If the meter's housing is damaged due to dropping or other external influences, remove the rechargeable battery or power supply and contact your local dealer or GOSSEN-Service for repair.



Avoid any and all contact with liquid crystals.

If the display is damaged (e.g. broken), danger of injury due to contact with glass shards or discharge of liquid crystals exists. Make sure that skin, eyes and mouth do not come into contact with the liquid crystals.

CD ROMs

The CD ROMs included with your measuring device contain relevant documentation and software. These CD ROMs cannot be played with an audio CD player, because they do not contain any audio files. When CD ROMs are played with an audio CD player, interference signals may be generated which lastingly damage human hearing or the audio components of your stereo system.



Handle rechargeable batteries with care.

Rechargeable and normal batteries may leak or explode if handled incorrectly. Please adhere to the following safety precautions:

- Make sure that the measuring device is switched off before removing or inserting rechargeable batteries. If the measuring device is used with a power supply, then, first of all, the power supply must be disconnected (pull the mains plug out of the electrical outlet).
- Only use the rechargeable batteries which are recommended for this meter.
- Make sure that the rechargeable battery is inserted correctly.
- Never short-circuit rechargeable batteries, and never attempt to open a rechargeable or a normal battery.
- Do not expose the rechargeable batteries to excessive heat or open flames.
- Do not expose the rechargeable batteries to moisture; never immerse rechargeable batteries in water.
- If the meter is not used regularly, remove the rechargeable battery and close the battery compartment cover
- Never store rechargeable batteries together with metallic objects which might cause short-circuiting.
- Danger of leakage exists, especially in the case of empty rechargeable batteries. In order to prevent damage to the measuring device, rechargeable batteries should be removed when fully depleted or in case of lengthy periods of non-use.
- When not in use, rechargeable batteries should be stored in a cool place.
- Rechargeable batteries heat up during use and may become hot. Be careful not to burn yourself when removing rechargeable batteries. Switch the measuring device off or wait until it has shut itself down, and then wait a bit longer until the rechargeable battery has cooled down.
- Do not use rechargeable batteries which show any signs of damage such as discoloration or deformation of the housing.

Notes

- Reproduction of product documentation or duplication of any excerpts from the same requires the express consent of GOSSEN Foto- und Lichtmesstechnik GmbH. This also applies to duplication in any electronic format and translation into other languages.
- Documentation is subject to change without notice.
- GOSSEN assumes no liability for damages resulting from incorrect use of the product.
- Documentation for your GOSSEN measuring device was prepared with the greatest of care. If you should nevertheless discover errors, or if you would like to suggest any improvements, GOSSEN would be very pleased to hear from you. (The address of your local GOSSEN representative is listed separately.)

Icon for separate collection of recyclable materials / hazardous waste in European countries



This icon indicates that this product must be disposed of separately.

The following must be observed by users in European countries:

- This product may only be disposed of separately at a designated collection point. It may not be disposed of with household trash.
- For further information contact your local dealer or waste disposal authorities.

The following icons are used in order to make it easier to find additional information:

!!	Important safety precautions: Please read these safety precautions before using the measuring device in order to avoid damaging your MAVOSPEC.
!	Important information which you should also read before using your MAVOSPEC
i	Notes: additional, useful information regarding use of your MAVOSPEC
➔	Reference to other information included in these operating instructions
M	Individual functions which can be configured in the menu

1 Preparation

1.1 Overview

Changeable measuring head

Turn to the left to remove the measuring head or to the right to attach one.

Touch screen display

Displays the measurement results and allows the control of the device.



Power / Measure / Back button

Press 1s to turn device on
Press 8s to turn device off in emergency situations - hard power off

During operation button has back or measurement functionality, depending on the selected menu.

Micro SD card slot

Micro SD card can be used to store measurement data or to update software.

Mini USB port

for connecting device to PC and share measurement data or interact with the software GL SpectroSoft.

1.2 Charging Instructions and Battery Care

To fully enjoy the enhanced hi-power capabilities, a device should be charged for about 2 hours by connecting the USB cable to the mini USB port of the device and the mini USB power supply attached to device on the other side and connected to the mains. A device should be turned off. When a device is turned on, the charging process takes much more time.

i

When MAVOSPEC operates, it discharges battery even if it is connected to your PC with USB cable. Please charge your MAVOSPEC with supplied charger. It could take few hours to fully charge the device.

Power supply specification:	Input	AC 100-240V 50/60Hz 0.15A
	Output	5V-1A

2 MAVOSPEC Software

The MAVOSPEC software allows you to make measurements of light sources, store and present them in a tabular or graphic form and calculate chromaticity parameters. It works as an Android application and its use is similar to other applications for phones and devices based on the Android system.

2.1 Home Screen

On the home screen, you can choose one of the following functions, which will be described further on.

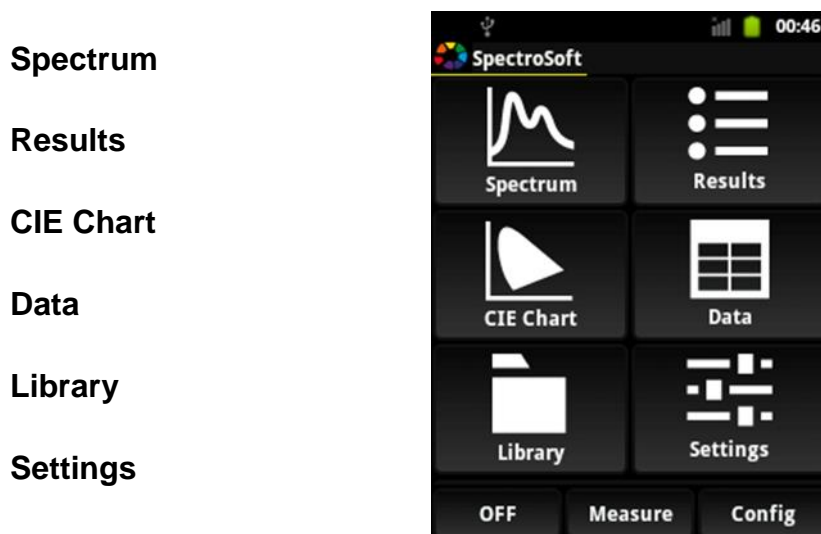

Spectrum

Results

CIE Chart

Data

Library

Settings

Most screens have a bottom button bar which features the buttons:

Back closes current screen and goes back to the previous one. On the main screen it changes to an “**OFF**” button which turns the device off.

Measure takes a measurement.

Config change measurement parameters

2.2 Config Screen

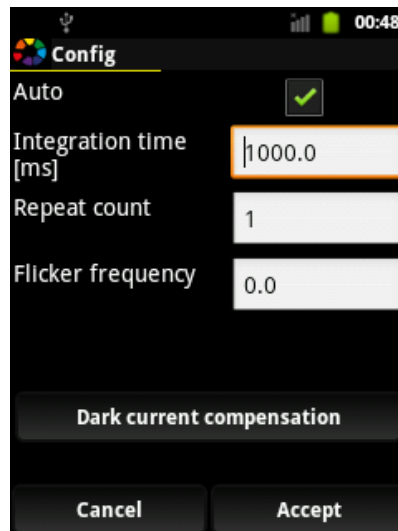

The following measurement parameters can be set on the config screen:

- Auto** Device automatically selects integration time. When this field is checked, the integration time parameter is omitted.
- Integration time** Duration of the light measurement.
- Repeat count** Number of measurements which will be used to calculate average light signal.
- Flicker frequency** Flicker frequency of a measured light source in Hz. Set 0 for non-flicker light source.
- Dark current** Allows the calibration of the device. The device measuring head must be attached during this procedure.

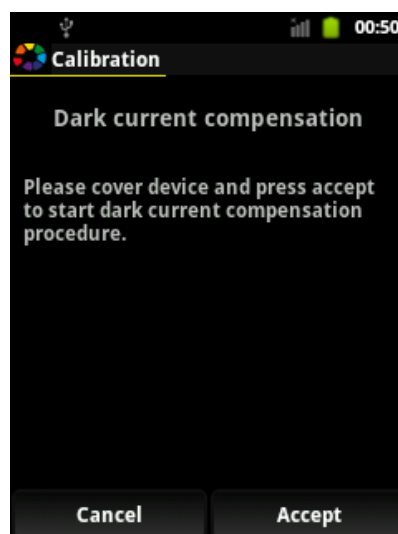

2.3 Spectrum Screen

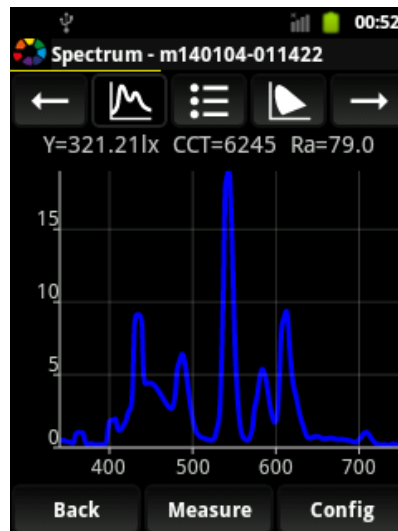

The Spectrum screen presents the spectrum chart of a measurement with several parameters at the top. The name of the measurement being presented is always shown in the title bar next to the GOSSEN icon.

Screens which present measurements are equipped with a quick navigation tool bar.



The quick navigation toolbar allows you to navigate between measurements in the current directory and select another presentation screen.

The available buttons on the quick navigation toolbar are as follows:



Previous measurement in current directory



Spectrum screen of the current measurement



Report screen of the current measurement



CIE chart screen of the current measurement



Next measurement in the current directory

2.4 Results Screen

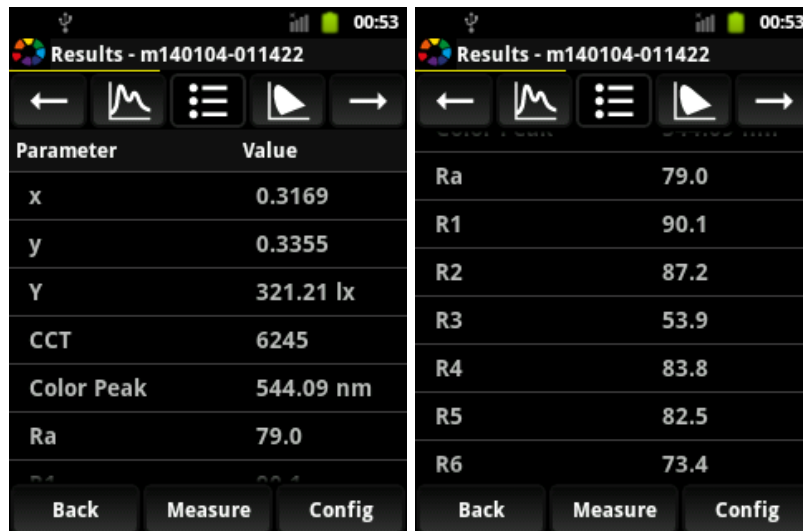

The Results screen presents calculated chromaticity parameters which describe a measured light source.

2.5 CIE Chart Screen

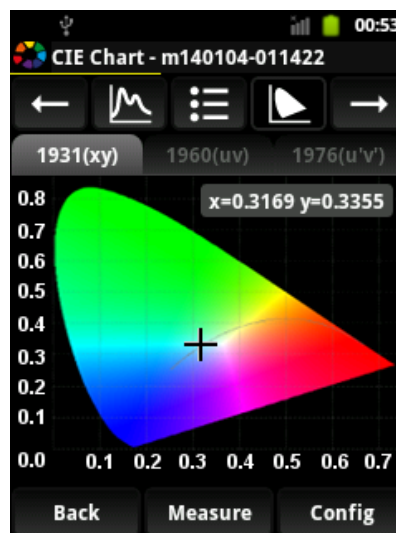

CIE chart screen shows chromaticity parameters on CIE chromaticity diagrams.

2.6 Data Screen



The screenshot shows a mobile application interface for a data screen. At the top, the title is "Data - m140104-011422". Below the title is a navigation bar with icons for back, a spectrum graph, a menu, a play button, and forward. The main content is a table with two columns: "Waves" and "Values". The table contains six rows of data. At the bottom, there are three buttons: "Back", "Measure", and "Config".

Waves	Values
340.21	0.46
342.09	0.46
343.97	0.50
345.85	0.49
347.73	0.43
349.61	0.42

The Data screen presents a table of spectrum data corresponding to a measurement. First column shows the wavelength, the second column the signal level.

2.7 Library Screen

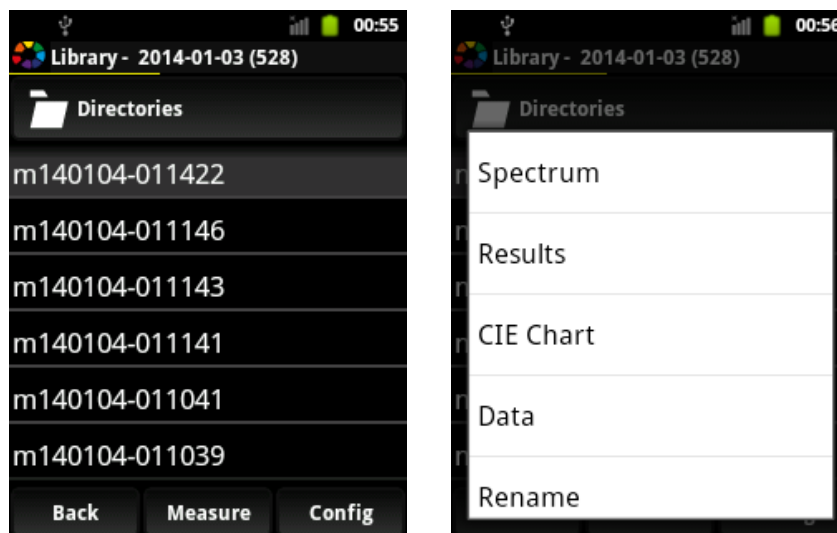

The Library screen shows measurements in the current directory and allows selecting the measurement which is displayed on the presentation screens. After a selection is made (by tapping the desired line), the measurement is displayed on the spectrum screen and is set as the current one. Any measurement taken is automatically set as the current measurement.

When you tap a measurement on the list and hold it for a while, the **context menu** is displayed. The Context menu provides you with a set of functions available for a selected measurement.

2.7.1 Directories Screen

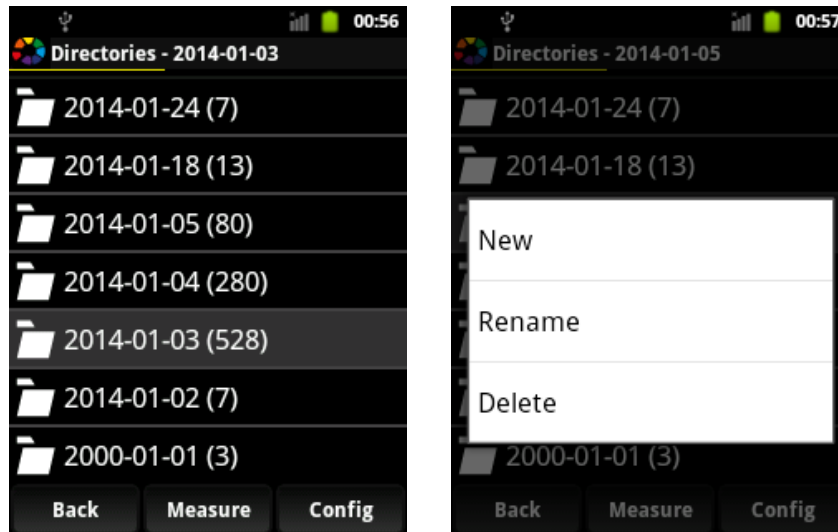

The directories screen shows directories in which the measurement results are stored. It also provides you with any easy tool to manage them. They are created automatically on the micro SD card where the measurements are collected and named using the date on which they were taken. You can manage directories using the **context menu**.

2.8 Settings Screen

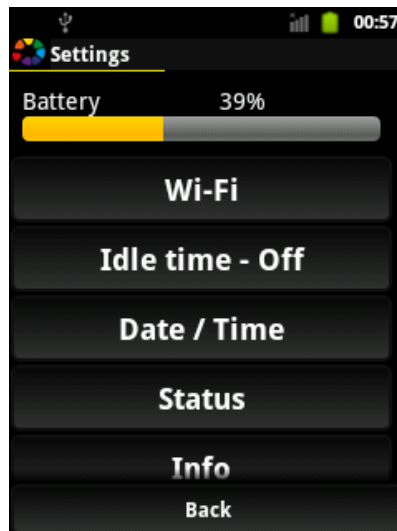

System settings as data, time or Wi-Fi configuration can be edited in the Settings screen.

2.8.1 Battery Status

Battery status shows the current battery level. Battery level is also shown below title bar as a line. Depending on the battery level it has color green (high level) , yellow (medium level) or red (low level).

2.8.2 Wi-Fi Settings

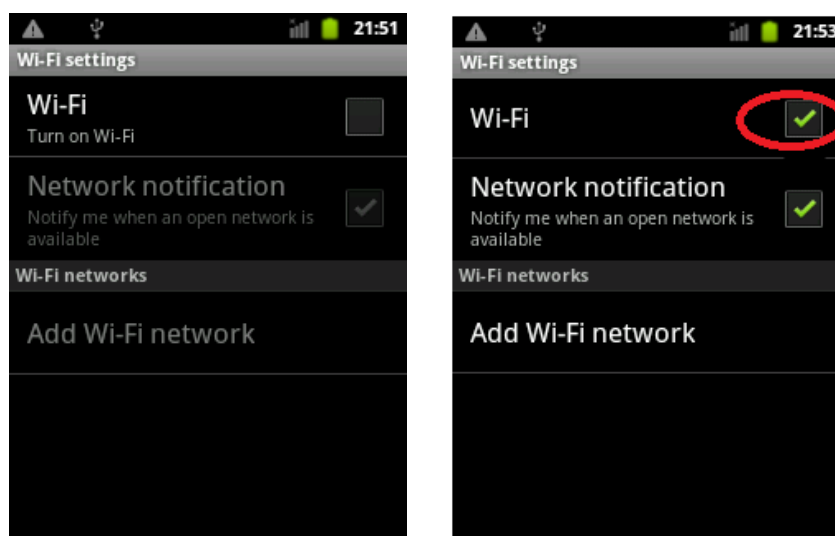

For activating WiFi tap on the related box.

Locate your wireless network name (SSID). Tap on your wireless network's SSID.

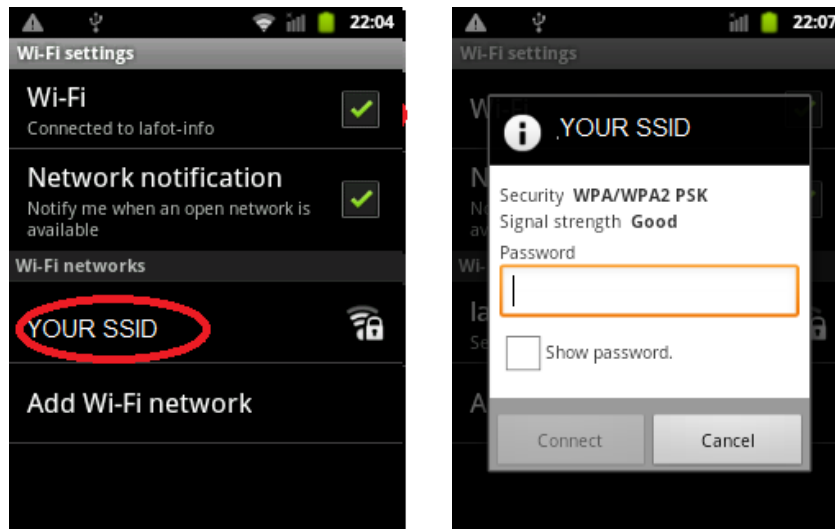

If your wireless router requires a key or password, the prompt on the right side should appear and you should enter the password.



Some keys/passwords are case-sensitive, so if it fails to connect, please make sure you use uppercase and lowercase letters appropriately.

If you are successful, it should show the word **Connected** underneath your wireless router's SSID on this list. You should also see a status indicator icon on the top task bar. When the device is connected to Wi-Fi network, IP address of the device should appear in settings.

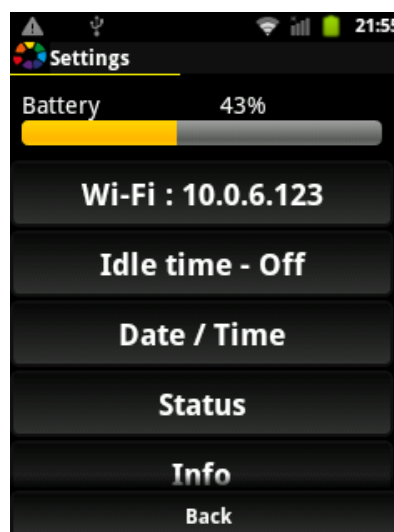

2.8.2 Idle Time

Idle time can be set to turn off the device automatically after the selected time and to lengthen operating time for battery. If idle time is off the device works until manual turn off.

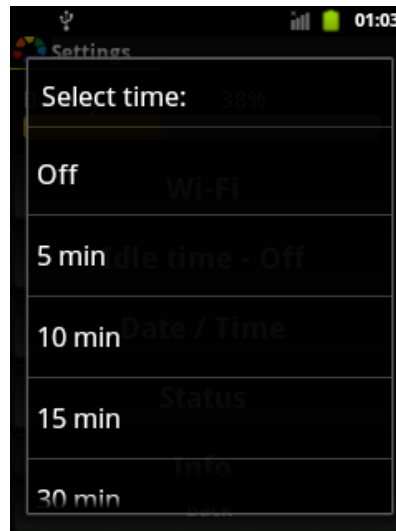

2.8.3 Date & Time Settings

Several settings for time and date as well as the formats can be done in this screen.

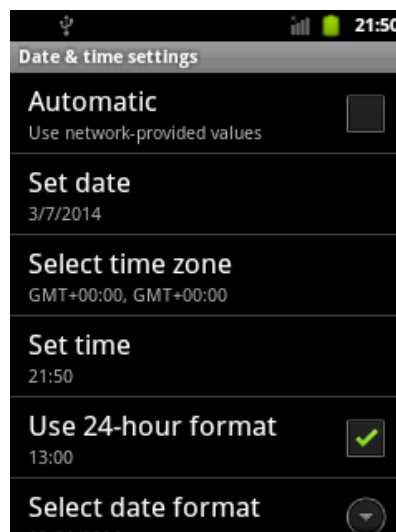

2.8.4 Status

This screen shows the status of the last measurement.

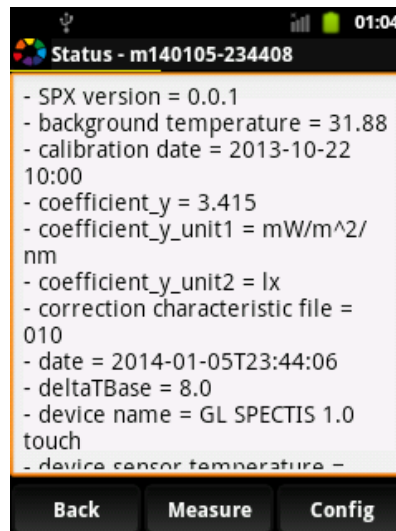

2.8.5 Info

Device information is shown in this pop up menu.

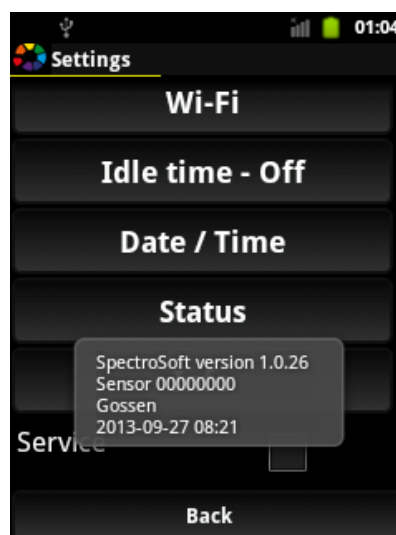

3 Trigger Input / Output

MAVOSPEC is equipped with input and output signal lines dedicated for starting measurement from external device and triggering external devices when measurement is started.

Trigger In line - high state on this line causes the same effect as pressing button on the device.

Trigger Out line - at the measurement start MAVOSPEC sets high state on this line. The high state is maintained throughout the period of measurement.

Trigger lines state:

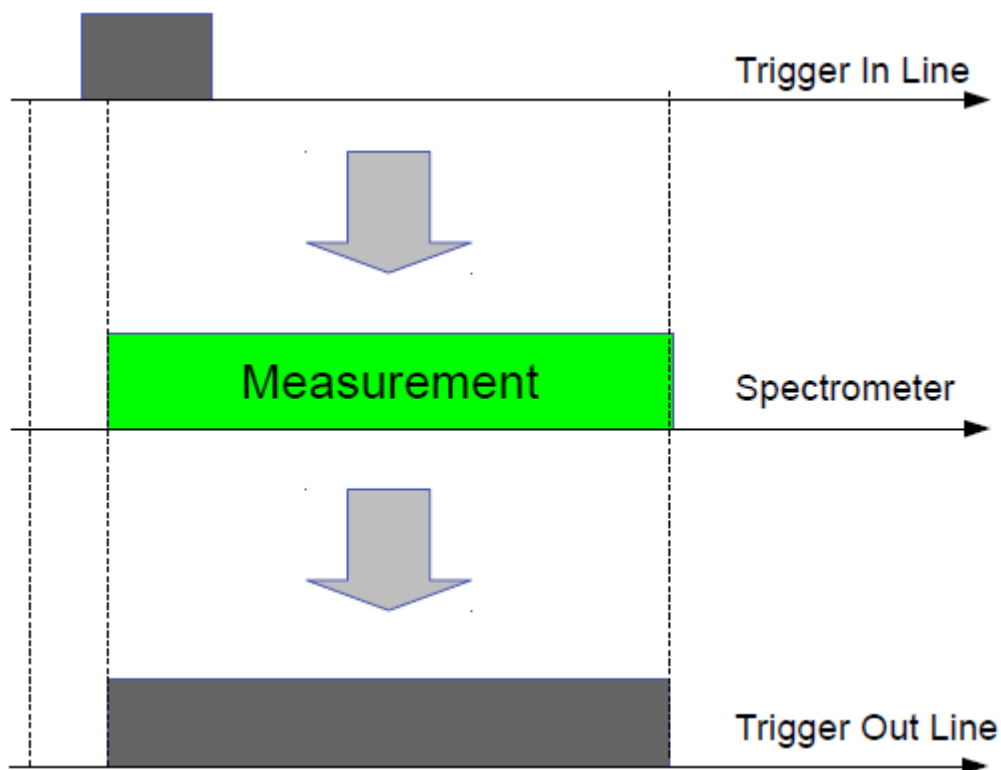

Trigger Technical Data	
Connector	Minijack 3.5mm, stereo, 3-pin
Trigger in line	Input line, type open collector with galvanic isolation. Voltage 4.5 ... 9 V. Min current 1 mA
Trigger in signal	Recommended high state $\geq 50 \mu\text{s}$,
Trigger out line	Output line, type open collector with galvanic isolation. Voltage 3 ... 9 V. Recommended current $\leq 1 \text{ mA}$

Pin allocation – stereo mini jack plug 3.5 mm

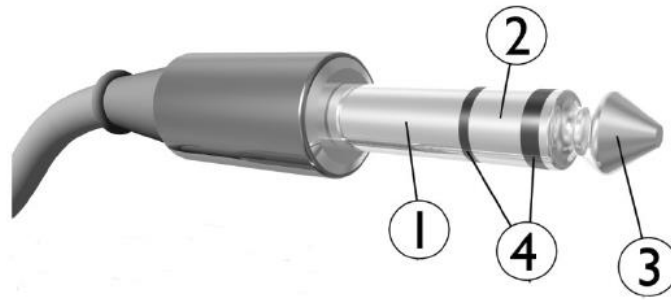

1. Sleeve - **GND**

2. **TRIGGER OUT**

- Open collector (Optocoupler TLP 127 - Darlington transistor).
- Maximum Collector current: 50 mA.
- The transistor is turned on during the measurement

3. **TRIGGER IN**

- The measurement is triggered by the rising edge of voltage (3 - 9V)

4. Isolating rings

Circuit diagram:

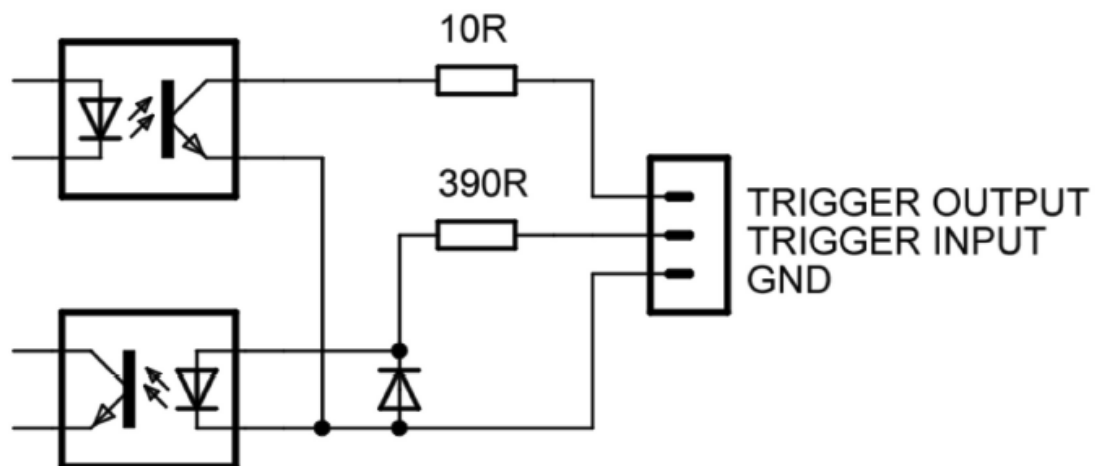

Possible wiring diagrams:

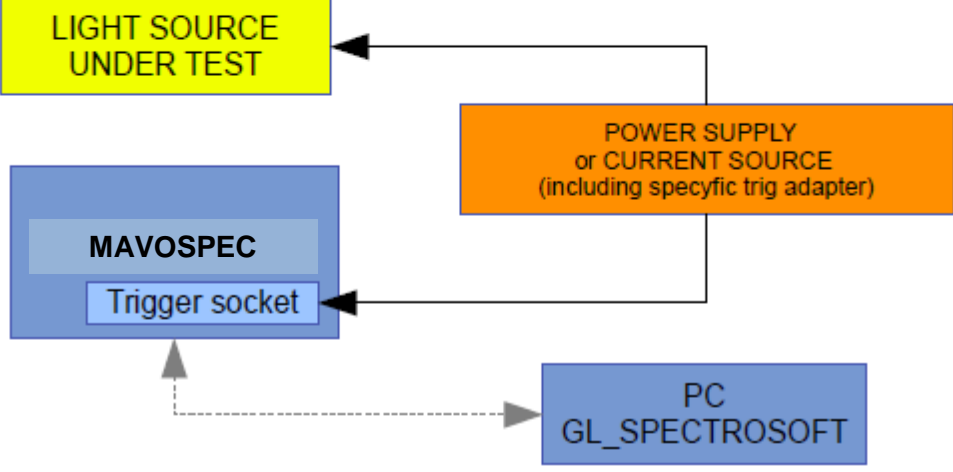
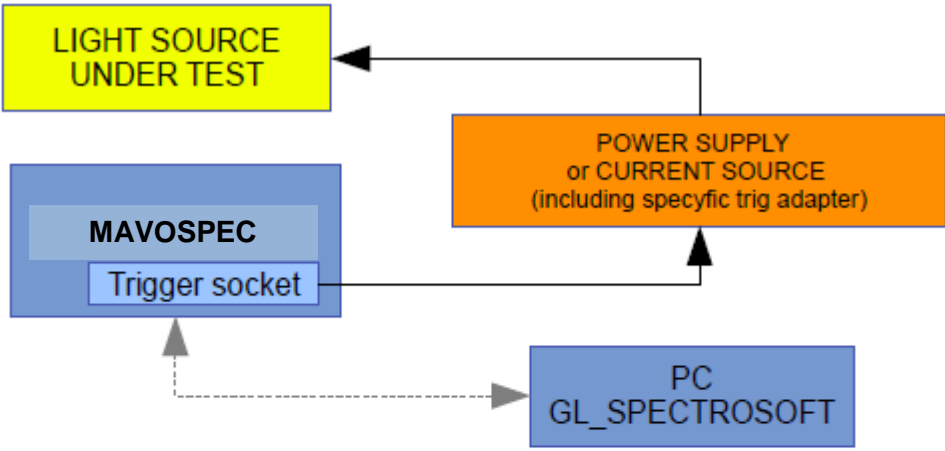

4 Accessories

The MAVOSPEC can be combined with different accessories for various measurement purposes. The device is equipped with a coder for the automatic detection of an attached accessory and for automatic calibration file download.

When you purchase your MAVOSPEC with accessories, factory spectral calibration is included in the price. Simply remove the standard measuring head and you can attach any add-on to the spectrometer. When connected to the computer, the software will recognize the unit and automatically download the proper calibration file.

i

If you purchase the accessory separately, remember to send your spectrometer to us for factory calibration. Separate charges will be applied.

4.1 Integrating Sphere – MAVOSPHERE 48 (M601A)

MAVOSPHERE 48 is an MAVOSPEC accessory for luminous flux measurement of LEDs and other small light sources.



The set includes the sphere in housing with a coder for automatic detection of the accessory. It is delivered with the certificate of factory absolute spectral calibration.

Installation and startup

1. Remove the standard measuring head delivered with your MAVOSPEC.
2. Put on the adapter and then attach the sphere in an up-right position.
Use the screw at the bottom of the sphere to firmly fix the add-on.
3. When connected to the computer the system will recognize the unit and download the proper calibration file.

i

If you need to measure bigger light sources, there are a lot of other integrating spheres in diameters from 205 mm up to 2000 mm available. Please ask for the accessories MAVOSPHERE 205, MAVOSPHERE 500, MAVOSPHERE 1100, MAVOSPHERE 2000

4.2 Display Sensor – MAVOPROBE 1.0 (M602A)

MAVOPROBE 1.0 is an MAVOSPEC accessory luminance measurement of flat LCD, OLED panels and plasma FPDs. It is also a perfect solution for testing projection displays as well as for OLED light source measurement.



The set includes an optical measuring probe, fiber optics and adaptor for the mini-spectrometer with a coder for automatic detection of accessory calibration file. The measuring probe can be installed on a tripod for distance measurements. Alternatively, it can be hanged directly on a screen with the use of a special stripe for contact measurements.

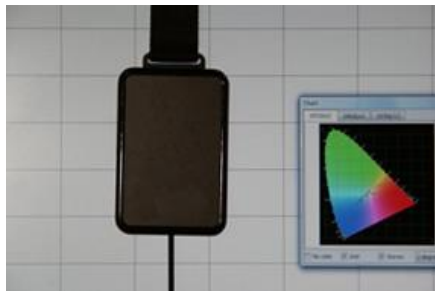

Installation and startup

1. Remove the standard measuring head delivered with your mini-spectrometer.
 2. Put on the adapter and then attach the sensor with a fiber optics.
 3. We recommend using the display sensor always in an up-right position in order to minimize the influence of polarization on your measurements.
 4. At the side of the sensor you will find the standard photo thread which can be used for installation on tripod.
 5. Additional stripe with counterweight can be attached by putting the plastic clip into the slot.
3. When connected to the computer the system will recognize the unit and download the proper calibration file.

4.3 Software – GL SPECTROSOFT BASIC (M603A)

GL SPECTROSOFT BASIC is an operation and evaluation software for MAVOSPEC with standard functionalities. The installation program for the software GL SPECTROSOFT is part of the CD in the standard delivery. The license has to be purchased separately and is copy protected by an USB dongle.



GL SPECTRASOFT BASIC standard functionality:

- **Spectral power distribution** – graphic display of the spectrum with scaling function and assignment of colors to wavelengths.
- **Tabular measured value display** – table with spectral data in native or calculated step sizes of 1, 2 or 5 nm
- **Evaluation of the spectra** – calculation of photometric and colorimetric quantities, chromaticity (XYZ; x,y; u',v'; CIELab), correlated color temperature, chromaticity error, peak wavelength and value, dominant wavelength, color rendering index Ra and individual indices R1 through R14
- **Chromaticity display** – in in the CIE standard color table, CIE 1931 [x,y], CIE 1960 [u,v] or CIE 1976 [u', v'] with a selectable standard observer of 2° or 10°
- **Basic photometric quantities** – depending on utilized accessories, illuminance, luminance or luminous flux is calculated from the spectrum.
- **Personalized measurement reports** – can be generated in HTML format for the momentarily displayed measurement for the purpose of documentation.
- **Remote control of and data transfer** – for the MAVOSPEC via USB or WiFi interface. Individual, continuous and interval controlled measurements are supported.
- **Universal exchange of spectra** – externally generated spectra can be imported from TXT files and subsequently evaluated. Internal data can be exported via TXT files or the clipboard and processed with other applications.
- **Individually configurable desktop** – individual windows can be arranged and scaled as desired, and saved as a configuration.
- **International use** – selectable user interface language: German, English, French, Italian or Polish

4.4 Software – GL SPECTROSOFT PRO (M603B)

GL SPECTROSOFT PRO is an operation and evaluation software for MAVOSPEC with an enhanced range of functions. It includes all of the GL SPECTROSOFT BASIC functions. The installation program for the software GL SPECTROSOFT is part of the CD in the standard delivery. The license has to be purchased separately and is copy protected by an USB dongle.



GL SPECTRASOFT PRO enhanced functionality:

- **LED binning** – brightness and color bins can be set up with the integrated editor. LEDs are assigned to the predefined classes during measurement.
- **Indices of metamerism** – are ascertained for the UV and visible ranges.
- **Approval of color matching stations** – measured quantities required in accordance with ISO 3664 are ascertained during the course of a test run and an approval report is generated.
- **Candle power (cd)** – calculation of candle power via the illuminance measurement with standard diffuser and specified distance.
- **Transmission and reflection** – of optical components can be implemented with an external light source and optical measuring accessories.
- **Measured values at a glance** – selectable measured quantities can be displayed in a special window.
- **Clear-cut comparison** – selectable measured quantities from various measurements can be summarized in a table and displayed in a special window.
- **MacAdam ellipse** – in preparation

•
i

If you have further requirements for the GL SPECTROSOFT, like special functions for your measuring and testing process, specific reports or further measurands that can be calculated from the spectrum, please ask us for customer specific adaptations.

5 Calibration

The MAVOSPEC with intuitive user interface is one of the most accurate and reliable spectrometers in its class, and reflects the most up-to-date technology available on the market. Before shipment, each spectrometer is photometrically and radiometrically calibrated together with any optional ordered accessories.

Like all other precision light meters, this product also requires regular maintenance, recalibration and software updates in order to continuously fulfill performance capabilities within the tolerances and specifications stipulated by the manufacturer.

GOSEN recommends a calibration interval of once every 12 months.

5.1 Spectral Calibration and Maintenance (H 997I)

The spectral calibration and maintenance covers the MAVOSPEC with standard diffusor. If additional accessories should be calibrated as well, there are extra costs for the calibration of the accessories.

5.2 Factory Calibration Certificate Luminance or Illuminance (H997B)

The traceability of the measuring results is guaranteed by our calibration reference: Scientific Standard Lamps, type Wi 41G of the PTB (Physikalisch Technische Bundesanstalt Braunschweig – National Standard Institute of Germany).



5.3 DAkkS Calibration Certificate Illuminance (H997D)

With our calibration laboratory accredited according to ISO/IEC/EN 17025 for illuminance (registration number D-K-15080-01-00) of DAkkS we can offer you the highest industrial level for the performance and traceability of calibrations for light metering.

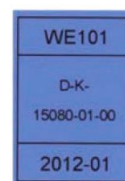

If you have questions or need more informations about the calibration service, please visit the GOSEN website or call the GOSEN service department.

6 Service and Maintenance

No special maintenance is required, if the MAVOSPEC is handled correctly. Keep the outside surfaces clean. Use a slightly dampened cloth for cleaning. Do not use cleansers, abrasives or solvents.

Should the device not work to your satisfaction, please send it to:

GOSSEN Foto- und Lichtmesstechnik GmbH

Lina-Ammon-Str.22 | 90471 Nürnberg | Germany

Phone: +49 911 8602-181 | Fax: +49 911 8602-142 | E-Mail: info@gossen-photo.de

www.gossen-photo.de

or to the **GOSSEN** distributor in your country. You can find the address of the local GOSSEN distributor on our website under www.gossen-photo.de.

7 Technical Specifications

Photometry

Application	Daylight, LEDs, halogen and more
Illuminance [lux]	1 lx ... 200 000 lx
Illuminance class	Class B – DIN 5032-7 Class AA – JIS C 1609-1:2006
Error limit – cos like rating (f2')	1.9%
Distance, diffuser to surface to be measured	29 mm
Luminance [cd/m²]	1 cd/m ² ... 10 000 cd/m ² , optionally with MAVOPROBE 1.0
Luminance measuring method	Distance / contact
Lumen – luminous flux	Optionally with MAVOSPHERE
mWatt – spectral power value	Optionally with MAVOSPHERE
CRI – color rendering index per CIE	Ra, R1 ... R14
CCT – correlated color temperature per CIE 13.3	■
Peak wavelength	■
Dominant wavelength	Optionally with GL SpectroSoft
Chromaticity coordinates [x,y] per CIE 1931	■
Chromaticity coordinates [u',v'] per CIE 1976	■
Chromaticity coordinates [u, v] per CIE 1960	■
Chromaticity error	Optionally with GL SpectroSoft
Index of metamerism	Optionally with GL SpectroSoft
Binning	Optionally with GL SpectroSoft
Evaluation per ISO3664	Optionally with GL SpectroSoft

Technical Data

Spectral range	340 ... 750 nm (UV ... VIS)
Spectral range optional	640 ... 1100 nm (VIS ... NIR)
Sensor	CMOS image sensor
Number of pixels	256
Physical resolution	~ 1.7 nm / ~ 1.8 nm
Wavelength reproducibility	0.5 nm
Integration time	5 ms ... 100 s
A-D converter	16 bit
Signal-to-noise ratio	1000:1
Spurious light	2*10 E-3
Full width at half maximum (FWHM)	12 nm
Radiometric accuracy	4%
Flicker compensation	■
Temperature sensor and automatic zero-point correction	■
Chromaticity measuring uncertainty	0.0015
Tripod mount	■
Automatic detection of respective accessories	■

Interfaces and Memory

USB	USB 2.0
WiFi	802.11b/g
Bluetooth	In preparation
SD card slot	Micro SD
Measured value memory	Automatic / 4 GB micro SD
Data format	XML
Plug for fiber-optic cable	Optional SMA905D

Operation

Display	3.5" color LCD, 240 x 320
Operation	Touch-screen, also PC / notebook

Miscellaneous

Operating system	Android
Power supply via USB port	< 640 mA
Power pack	Mains power pack, 100 ... 240 V (50/60 Hz) 0.15 A
Battery / rechargeable battery	Rechargeable Li-ion battery, 1400 mAh
Rechargeable battery life	< 6 h
Charging time with charger / USB	2 h
Operating temperature	5° ... 35° C
Dimensions [H x W x D]	146 x 74 x 24 mm
Weight	315 g
Scope of delivery	Case, battery, USB cable, power pack, carrying strap, display protector, 4 GB micro SD card

Printed in Germany – Subject to change without notice

GOSSEN Foto- und Lichtmesstechnik GmbH | Lina-Ammon-Str.22 | D-90471 Nürnberg | Germany
Telefon: +49 911 8602-181 | Fax: +49 911 8602-142 | E-Mail: info@gossen-photo.de

www.gossen-photo.de